

TOWER BUILDER KIT: NEW BABYLON

BY DAVE GRAFFAM

SOME INSTRUCTIONAL TEXT

BY JERRY JENSEN

HOW TO USE TEXTURE LAYERS

This kit includes PDF files with multiple layers that contain a variety of graphics. You can adjust these layers to customize the final look of your models before you print them.

To adjust the layers, find the **Layers menu** in your PDF reader (I recommend the free program **Adobe Acrobat Reader**). Next, open or expand the **Layers Palette** to reveal the list of layers. Some of the layers will be visible to start off with, but most will be invisible. **Click on the  icon to make a layer appear.** Go through each layer turning it on and off to see what features you want to add or take away.

Note that the layers are stacked up, on one top of the other, like sheets of film. If you turn on a layer but you don't see any new graphics appear, it's because the layer you've just turned on is *below* some other layer you already have turned on. To reveal the new layer, you'll have to turn off the layer *above* it that's hiding it from view.

This PDF that you're reading now includes optional layers. Go ahead and try out what you've just learned on it. Open the Layers menu, open the Layers Palette, and start clicking away.

EXPERT ADVICE

Don't miss the **Paper Modeling Guide** available at **DavesGames.Net**, written by **Jerry Jensen**. It's loaded with clever tips and tricks to help you assemble great-looking models.

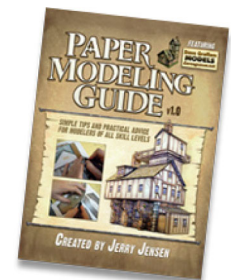



TOOLS

You'll need a few basic craft supplies to create this model.

- **Scissors:** Use scissors designed for cutting thick paper.
- **Hobby knife:** Use a hobby scalpel you're comfortable with. Replace the blade often.
- **Metal ruler:** Use a 12" metal ruler with non-slip backing.
- **Cutting mat:** A 12" x 18" self-healing vinyl cutting mat is the ideal cutting surface. A smaller 5" x 7" cutting mat may also come in handy.
- **Glue:** Use craft glues for paper such as PVC glue. My favorite is Aleene's Original Tacky Glue. For covering large areas, use cheap glue sticks.
- **Mat boards, illustration boards, or cardboard:** Some pieces in this kit should be reinforced with material that's sturdier than cardstock (although two layers of cardstock back-to-back will work if you really have nothing else to reinforce with). I recommend plain white or black mat board, or illustration board (single-weight or double-weight), or cereal boxes and other non-corrugated cardboards.

PREPARATION

Read through these instructions at least once before printing and assembling your model to help avoid any mistakes or confusion later.

Paper: To get the best results, experiment with different papers and printing methods. Take advantage of the brightest and sharpest printing methods you have available. I prefer laser color copies printed on 110# (199 gsm) matte cardstock.

Printing: These PDF files are set up for the standard 28mm tabletop wargaming scale (1 inch equals 5 feet), and for US letter-sized (8.5" x 11") and A4 sized sheets. To be sure, turn off any 'fit to page' options in your printer driver and test your settings with a black-and-white print.

SCALE	%
28mm	100%
25mm	85%
20mm	65%
18mm (HO)	60%
15mm	50%

For printing at gaming scales of smaller than 28mm, see the table above and adjust your printer settings.

Cutting: Always cut carefully and slowly. Use good sense when working with sharp tools, and keep them away from children. In this set, it's fine to use scissors to cut along edges that have no texturing. For edges that are textured, use a hobby knife for accuracy. To cut thick materials, score one once or twice, then make deeper cuts as needed.

Scoring: To score a line, lightly drag the tip (or even the back of the tip) of your hobby knife along that line. Use a cork-backed metal ruler as a guide for your knife.

Pre-fitting: After cutting and scoring each component, "crack" them along their score lines and fold them slightly in the proper direction. Whenever possible, use a flat surface such as your cutting mat to easily and cleanly fold each segment. This step will let you know if you have forgotten to score any lines.

Edging: Optionally, you may use a fine-line marker to darken the white edges of the components. This will greatly improve the overall appearance of your final model. Black markers will work well for most components, but you may experiment with other marker colors for even better results.

Paper Scraps: Rather than discarding all of your unused cardstock pieces, cut these into triangles or squares about 1 inch across. These can be useful for spreading glue evenly on tabs, by using the flat sides of the paper scraps as a trowel. And they can be used to put small amounts of glue exactly where you want them, by placing a dot of glue on the corners of a paper scrap.

STANDARD LEVELS

Follow these instructions to build standard levels with square or rectangular walls of 4" x 4", 4" x 6", 4" x 8", 6" x 6", 6" x 8", or 8" x 8".

Start with cardstock prints of 4 **standard walls** of your choice, making sure that the front/back walls have matching lengths (4", 6", or 8") and that the left/right walls have matching lengths (4", 6", or 8").

Cut out the wall pieces along their outer black lines, then score along the remaining black lines, and fold back along those lines (1). Do not cut out any interior white areas yet.

Join the walls into one long strip by affixing the side tabs (2). Cutting will be easier for you later if the wall piece furthest to the right does not have any white areas that need to be cut out.

Flip the long strip over. Starting from the right, fold down the first three interior wall sections and glue them flat (3).

When dry, carefully cut out any white spaces on these three wall sections only (4).

Affix the remaining side-tab on the strip to the opposite side, so that your strip becomes a boxy shape (5).

Fold down the last remaining interior wall section and glue it flat (6).

If you need to cut out any white spaces on that last wall piece, flatten the entire strip and insert a small cutting mat (or a few thick pieces of cardboard) underneath the wall section that needs to be cut (7).

STANDARD FLOORS

Print out the **floor** piece of the appropriate size.

Note: See below for special instructions when creating 8" x 8" floors.

Cut the piece out, leaving a little bit of white space around the piece's edges. Affix this to another sheet of cardstock, or to backing material such as mat board, illustration board, or cardboard. When dry, cut along the black lines (8).

Place the floor piece inside the walls (9). If you like, you may glue this piece in place permanently, or leave it loose so that your walls can be flattened for easier storage.

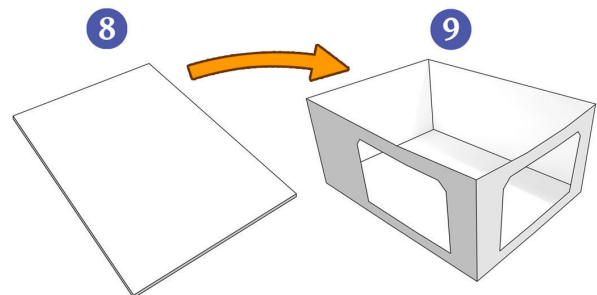
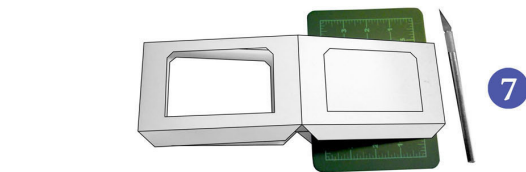
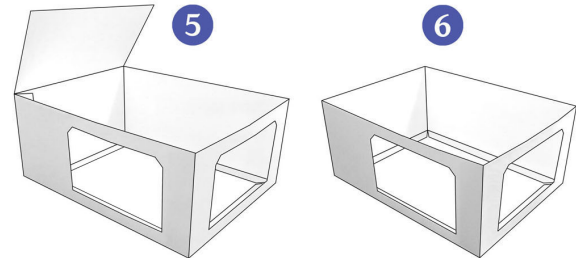
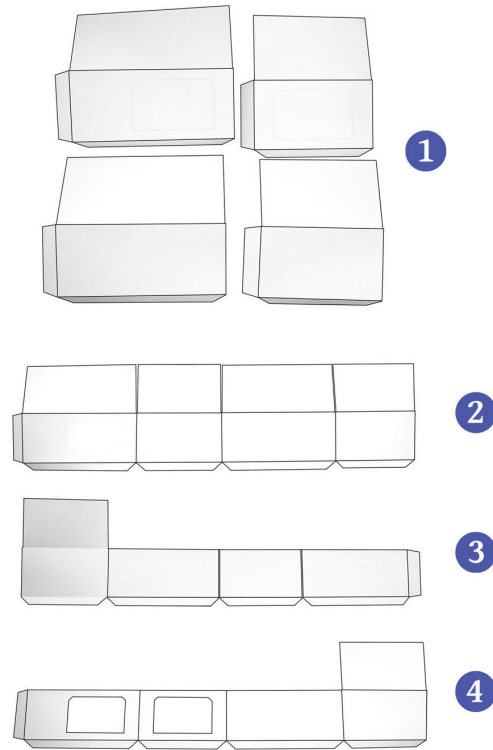

STANDARD ROOFS

Print a **roof cap** of the desired dimensions to match the top of one of your levels.

Note: See below for special instructions when creating 8" x 8" roofs.

Cut out the roof cap piece along its outer black lines, then score along the remaining black lines, and fold back along those lines (1).

Affix the tapered tabs on the roof cap, so that the piece is the shape of a shallow tray when upside down (2).

Print and cut out the **ceiling** piece. Optionally, you may affix this piece to sturdier material, then trim off any excess (3).

Affix it centered to the underside of the roof piece (4).

Note: See below for special instructions when creating 8" x 8" ceilings.

ROOF RAILINGS

Print four **roof railing** pieces of the styles of your choice.

Note: Plan ahead for the placement of stairs, doors, and other features you want for your towers, and choose your railings as appropriate.

Cut out the railing pieces, leaving some white space all around (5).

Score along the central line and fold back (6).

Fold the piece all the way over and glue flat (7).

When dry, affix the railings to the untextured sides of the roof (8).

Below are some examples of completed standard levels.

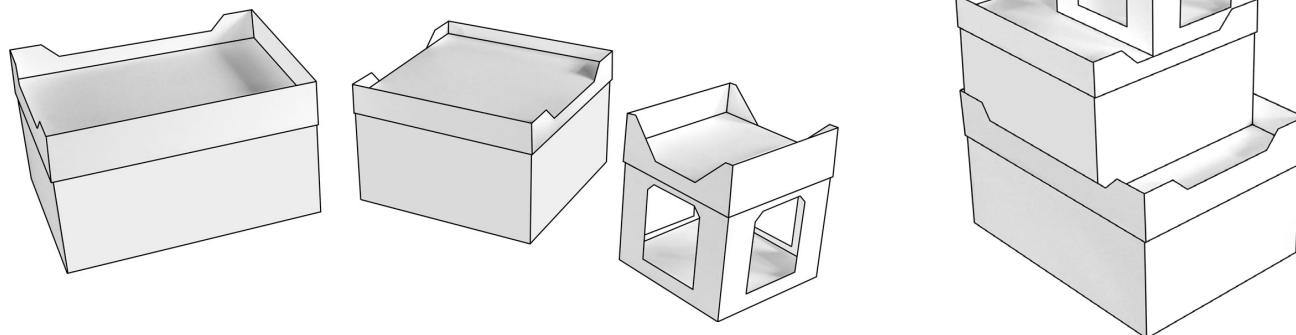
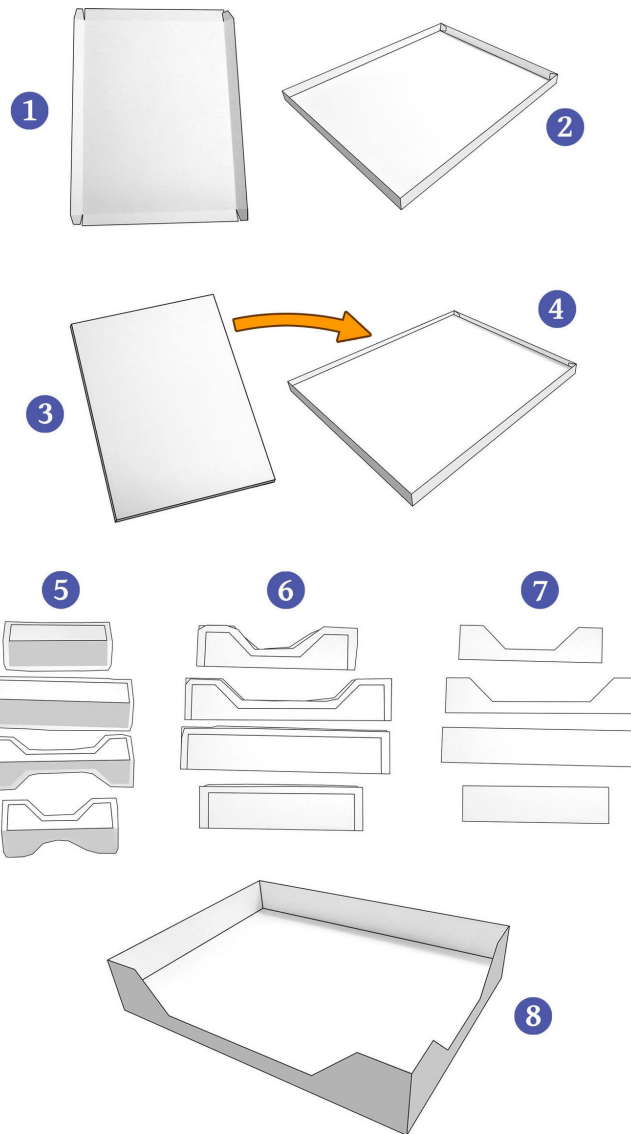

EXPANDING LEVELS

Follow these instructions to build expanding levels that are larger at the top than at bottom.

Start with cardstock prints of 4 walls. Your front wall must be a **standard level wall** (4", 6", or 8") and your back wall must be an **expanding back wall** of the same length. Your two left/right **expanding side walls** must also be of a matching length (4" to 6", or 6" to 8").

Note: The 8" expanding back wall is in two pieces, marked **A** and **B**.

Cut out the front standard wall and the two expanding side wall pieces along their outer black lines, then score along the remaining black lines, and fold back along those lines (1). Do not cut out any interior white spaces yet.

Affix the side-tabs on these pieces to form one long strip (2).

Fold down the interior wall sections and glue flat (3).

When dry, carefully cut out any white spaces (4).

Cut out the expanding back wall along its outer black lines, then score along the remaining black lines, and gently fold back along those lines (5).

Affix the long diagonal tab to the corresponding panels on one of your expanding side walls (6).

Gently **fold forward** on the lower panel on the expanding back wall, and affix it to the corresponding panel on the side wall (7).

Note: If your level includes an 8" expanding back wall (which will be in two pieces), affix piece **A** during steps 6-7, and affix piece **B** during step 7.

Continuing with the small panel at the top of the outer expanding back wall, affixing the remaining sections, folding forward as needed, to complete the walls (8).

To create the floor piece, follow the same process described for standard floors (above).

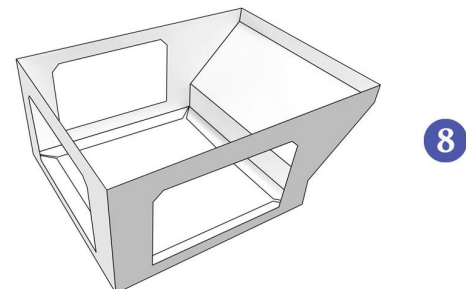
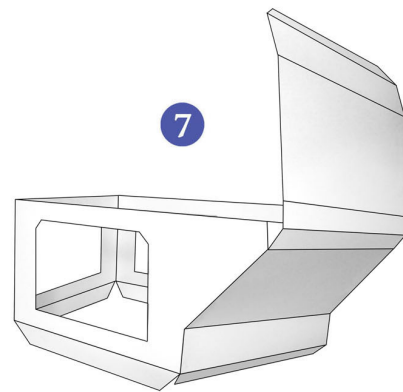
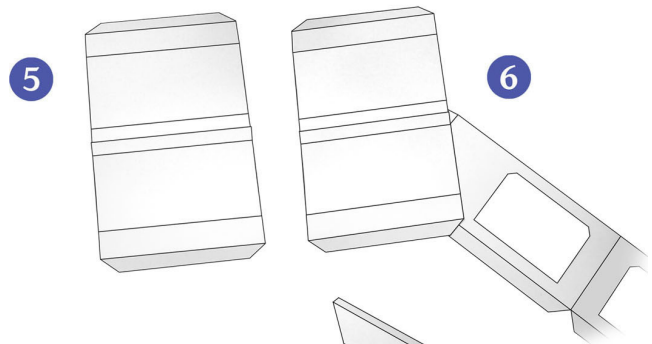
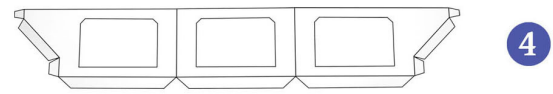
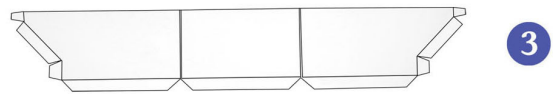
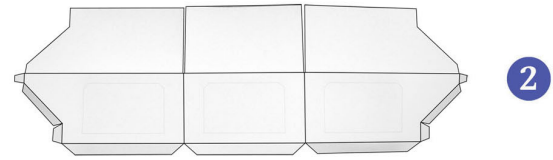
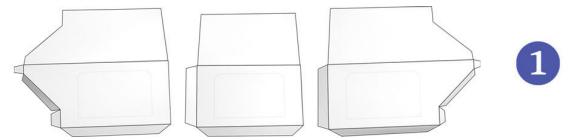

8" x 8" FLOORS

Print out two 4" x 8" *floor* pieces, cutting along their outer edges (1).

Affix these side-by-side to another sheet of cardstock (2), or to backing material such as mat board, illustration board, or cardboard.

When dry, trim off any excess backing material (3).

8" x 8" ROOFS

Print and cut out two 4" x 8" *ceiling* pieces along their outer black lines (4).

Affix these pieces side-by-side to sturdier material (mat board, etc.). When dry, trim off any excess (5).

Print two 8" x 8" *roof cap* pieces, and cut them along their outer black lines, then score along the remaining black lines, and fold back along those lines (6).

Place the two pieces side-by-side and connect them by affixing the two small tapered tabs (7).

Continue assembly just as you would for a standard roof (see above), folding up the edges of the roof cap so that it forms a tray, then affixing the ceiling piece within the tray, and finally adding railings.

A completed 8" x 8" level and roof should look something like the example below.

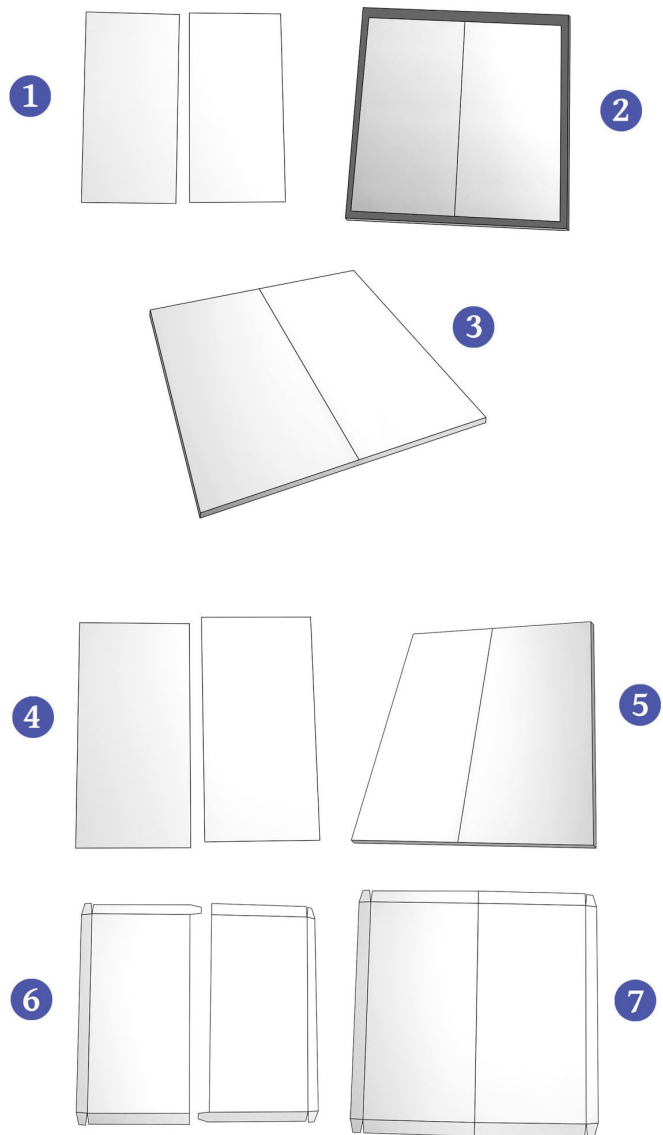
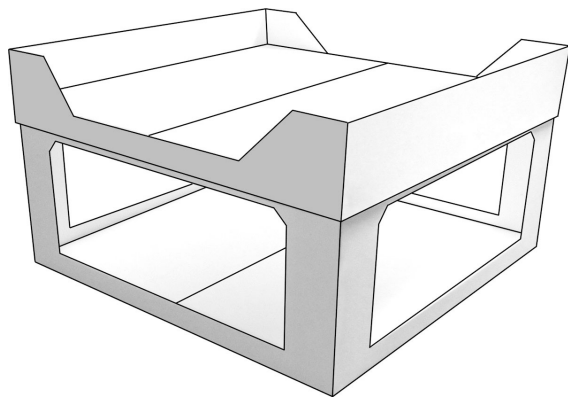

STAIRWAYS

There are two styles of stairways to choose from, one featuring steps that are 1/2" deep, and the other featuring steps that are 1/4" deep (which are more realistic, but more challenging to assemble). Both are assembled in essentially the same way.

Cut out the **stairway walls** piece along its outer black lines, then score along the remaining black lines, and fold back along those lines (1).

Fold up the back wall and affix the tabs in place (2).

Cut out the **stairway steps** piece along its outer black lines, then score the remaining black lines, but **do not fold back** on the lines. Affix the top step to the tab along the top of the stair walls (3).

Continue affixing the steps, starting at the top, folding forward or backward on the step panels as needed, like an accordian (4, 5).

At this point, your stairway can be placed inside or outside of any of the building modules in this kit.

The **stairway railings** are optional pieces, and you have several types to choose from.

Cut around your chosen stairway railings, leaving some white space all around (6).

Score along the central black line and glue flat (7).

When dry, cut along the outer black lines (8).

Attach the railings to the walls of your stairs depending on how you intend to use them. See below for some examples. You can glue the railings in place permanently, or use non-stick tape, blue-tack, or paperclips as a temporary solution.

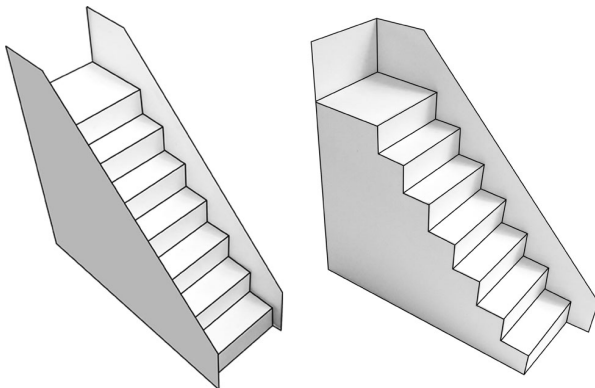
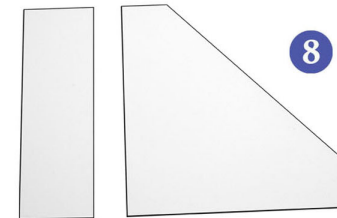
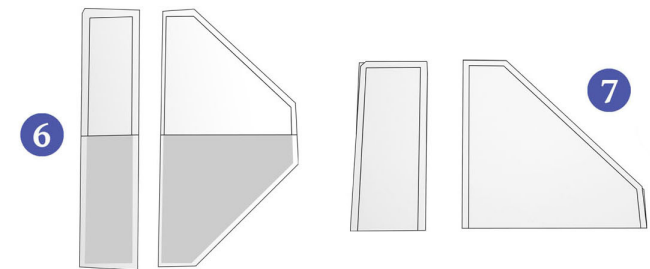
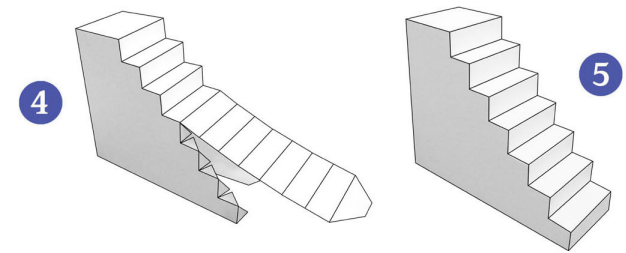
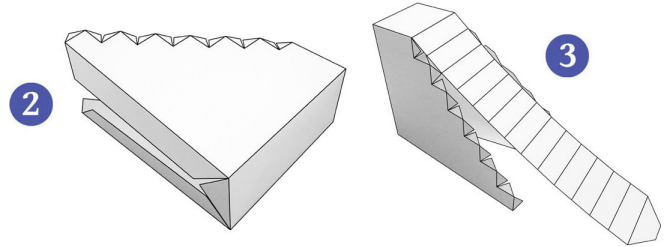
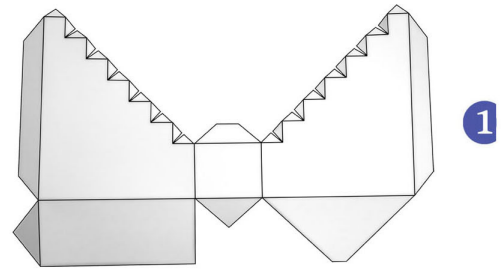

WALKWAYS

Cut out your chosen *main walkway* piece along its outer black lines, then score along the remaining black lines, and fold back along those lines (1).

Fold over the long underside panel and glue flat (2).

Fold up the main walkway into a boxy shape by affixing the small tapered tabs (3).

The walkway railings are optional pieces, and you have several types of railings to choose from. They are all assembled in the same way.

Cut out the railing piece, leaving some white space all around. Then score along the central line and fold back (4).

Fold the piece all the way over and glue flat (5).

When dry, cut out along the remaining black lines (6).

Affix the railing in place along the side of your walkway (7).

The ends of the walkways can be slipped between the roof and floors of other levels, bridging gaps between your buildings.

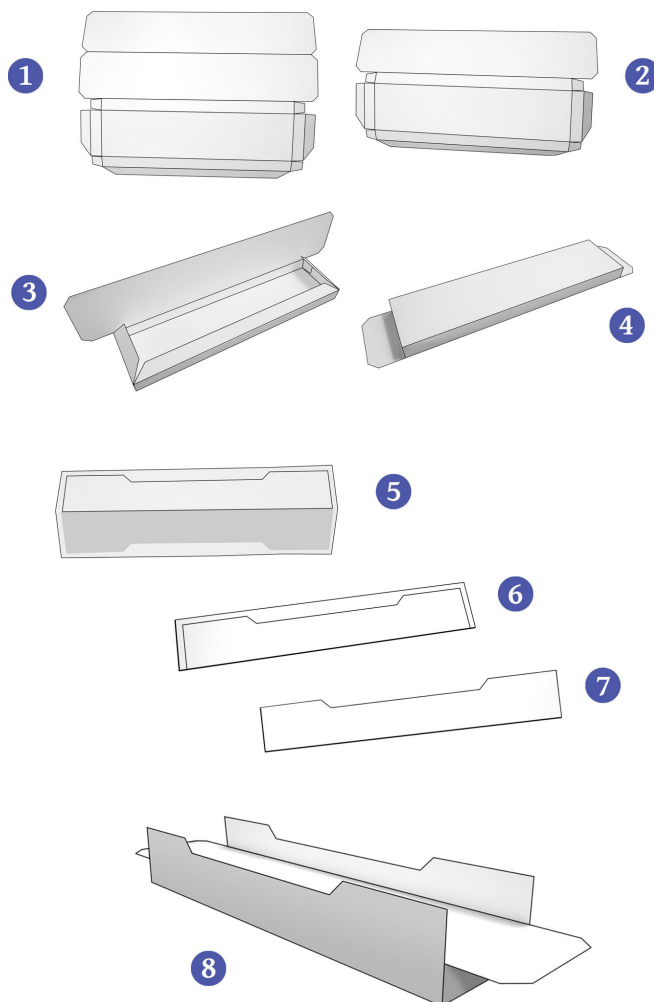

STORAGE TANKS

These can be placed nearly anywhere.

Cut along the outer black lines, then score along the remaining black lines, and fold back along those lines (1). Affix the long side tab to the opposite side, forming a tubular shape (2). Fold up the hexagonal caps on either end and affix in place (3).

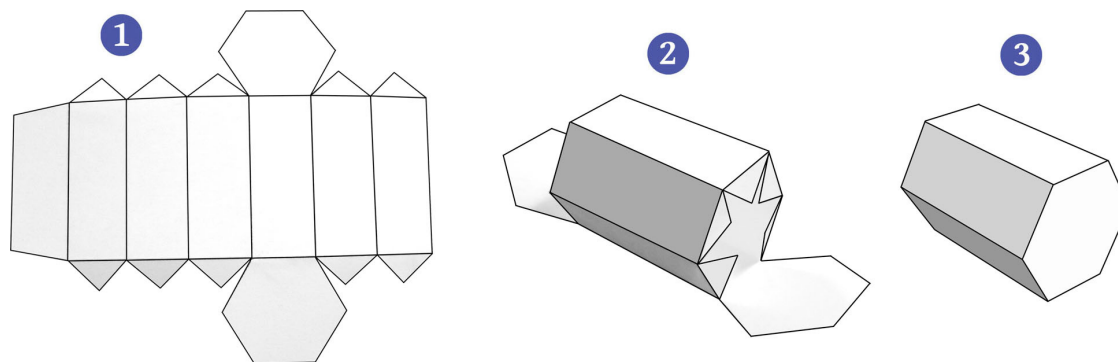

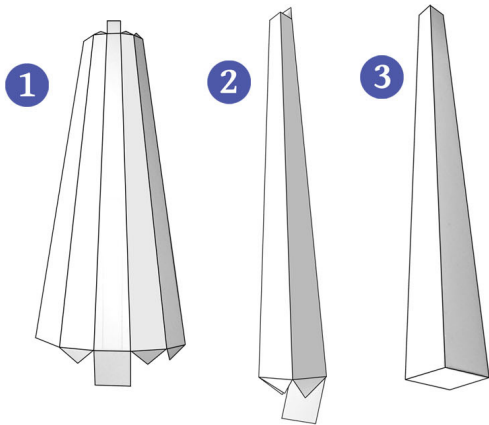

TRANSMITTER

These can be added to the roofs of tall structures, or as a ground-based comm stations.

Cut out the **transmitter aerial** piece along its outer black lines, then score along the remaining black lines, and fold back along those lines (1).

Affix the large tab to the opposite side, forming a tubular shape (2), then seal up the ends (3).

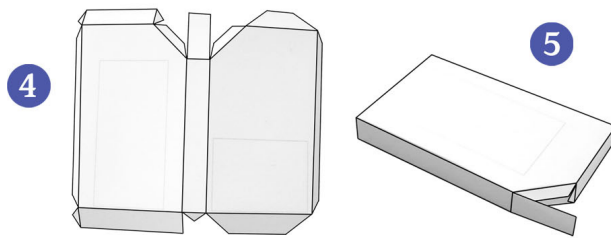

Cut out the **transmitter support** piece along its outer black lines, then score along the remaining black lines, and fold back along those lines (4).

Affix the tabs along the tops and bottoms, forming a flat boxy shape (5), then seal up the short angled tab (6).

Affix the support support to the transmitter aerial in the indicated position (7).

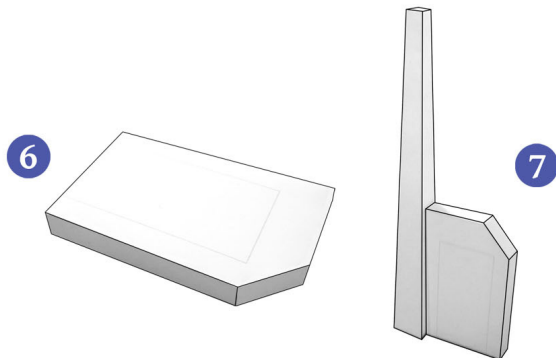

Cut out the **transmitter module 1** and **transmitter module 2** pieces along their outer black lines, then score along the remaining black lines, and fold back along those lines (8).

Affix the tabs along the tops and bottoms, forming a boxy shape (9).

Affix the modules to the transmitter support in the indicated positions (10).

